

Guidance notes for fixing



Plaster Membrane

OLDROYD

THE ULTIMATE WATERPROOF MEMBRANE SYSTEM



SECTION 1.0 SURFACE PREPARATION

Remove any damaged loose or crumbling materials from surfaces to be covered. Remove any protrusions likely to puncture the membrane or cause unnecessary undulations. If considered necessary apply an application of CBP Probor DB (a masonry biocide) over the surface to be covered, prior to fixing the membrane.

SECTION 2.0 MEMBRANE FIXING

Cut off required length of membrane from the roll allowing for a floor wall detail if required. If a solid floor is present we recommend that the membrane is dressed into the floor (see diagram 1).

Working from left to right, offer the membrane up to the surface to be covered keeping the 100mm strip of exposed membrane to the right. To facilitate easy working apply a temporary top centre fixing to pivot hang the membrane. Vertically plumb the membrane and then secure the top edge so that it now hangs square. At approximately the centre of the hanging length drill an 8mm diameter hole (or 7mm dependent upon the substrate) to a depth of not less than 70mm. Position a Oldroyd Plaster Plug Compression Seal on the membrane directly over the drilled hole then offer a Oldroyd Plaster Plug into the hole and gently tap home using a lump/club hammer until the head is flush with the mesh surface. Do not create a dimple by using excess force (see diagram 3).

To avoid rucking the membrane, continue fixing from the centre outwards securing horizontally and vertically at between 250mm and 300mm centres for internal use and 150mm for external use (see diagram 4). Refer to section 6 for appropriate centres. To avoid bulging pull membrane as tight as possible between fixing points. When curves or uneven surfaces are to be covered, closer centres will be required. Remove temporary top edge 'pivot' fixing and either seal hole or make into a permanent fixing using a Plaster Plug. Repeat process for each length of membrane.

At this stage do not locate fixings through an edge where an overlap or butt seam is required.

SECTION 3.0 JOINING MEMBRANE TO MEMBRANE. (SEAMS)

The joining of one sheet of membrane to another is a simple affair. When setting out a job thought should be given as to where the seams are likely to occur so as to avoid awkward positions such as very near to an internal or external corner though these may be overcome should it be unavoidable.

3.1 Standard Overlap Seam

Along one edge of the membrane is a strip approximately 100mm wide with no plaster mesh present. This area is designed for use in forming a standard overlap seam and no fixings should be in this area until the seam is being formed.

With the exposed strip of membrane to the right, fully fix the first sheet of membrane. Position the next sheet of membrane, again with the exposed strip of membrane to the right so that the mesh covered edge to the left fully

DIAGRAM 1
Solid Floor/Wall Detail

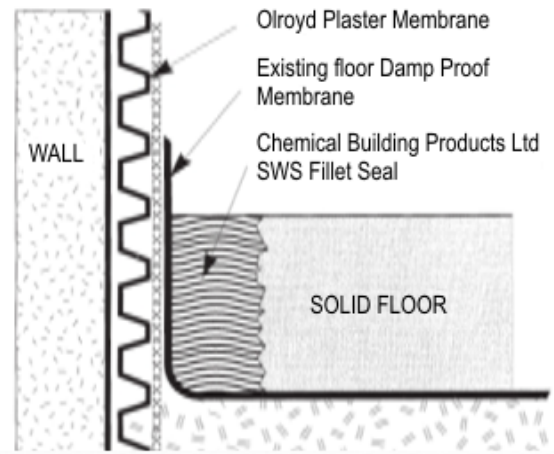

DIAGRAM 2
Oldroyd Plaster Membrane Plug and Compression Seal

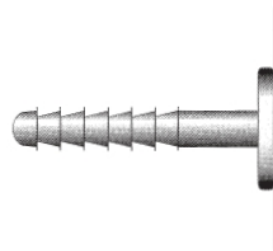

DIAGRAM 3
Plaster Membrane Plug Fixing

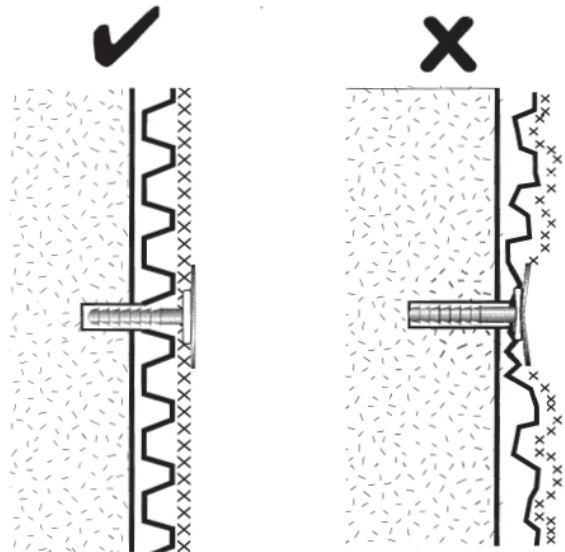
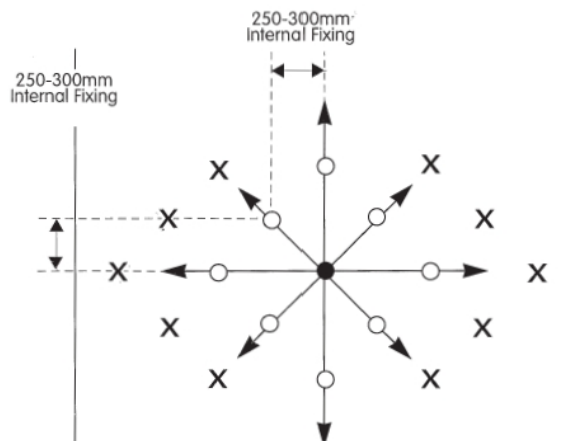

DIAGRAM 4
Work from the centre outwards



overlaps the underlying exposed strip of the first sheet. Continue to fully fix the second sheet of membrane as the first i.e. starting in the centre and working outwards. When it becomes necessary to fix the seam area where the two edges overlap, wipe the exposed strip and the underside of the overlapping area of membrane clean of dust. Apply Oldroyd Double Sided Tape centrally along the entire length of the underlying exposed strip. Starting from the middle of the seam, working outwards in both directions, tear and remove the backing paper from the double sided tape and gently apply firm pressure along the top membrane to ensure good adhesion. Use Plaster Plugs at appropriate centres to mechanically fix the seam along its entire length.

3.2 Butt Seam (see diagram 5)

On occasions it is necessary to form a mesh to mesh seam and this is referred to as a butt seam. Make sure both edges that will form the butt seam are cut in a straight line. Insert a strip of DPC or heavy gauge polythene at least 20cm wide halfway behind an already secured length of membrane leaving 10cm protruding. Offer the edge of the next length of membrane over the protruding 10cm of DPC/Polythene and butt join the two pieces of membrane together. Continue to fix membrane in the normal way but always ensure that adequate fixings at the appropriate centres are present along each edge of membrane.

On difficult internal and external corners a similar procedure may be adopted with the butt seam outlined above forming the actual corner. The DPC/Polythene behind the butt seam prevents moisture transmission via the plaster finish which will inevitably penetrate the butt seam.

SECTION 4.0 INCOMING SERVICES & PROTUSIONS

(See diagrams 6 & 7)

When it is necessary to cut the plaster membrane in order to accommodate a service pipe, or other protrusion, the cut should be as short as practically possible and made good with a waterproof mastic or the butt seam procedure outlined in section 3.2. At the point where the service actually penetrates the membrane adopt the following procedure:

Clean off and prepare/prime the incoming service or protrusion. Cut off a length of 20cm Oldroyd Overseal Tape approximately four times the cross sectional area of the incoming service. On the centre of the paper surface draw an exact profile of the pipe to be accommodated. Within the drawn profile area cut diagonally across at different points of least four times then a single cut out to the nearest edge to form a "collar" (see diagram 6). Remove paper backing and offer the collar over the incoming service with the sticky face outwards. Use Oldroyd Rope or Double Sided Tape to seal the collar to the incoming service at the point of entry (see diagram 7). Prepare and offer the membrane over and around the incoming service/protrusion and press it onto the sticky face of the "collar" surrounding the service entry.

DIAGRAM 5
Butt Seam

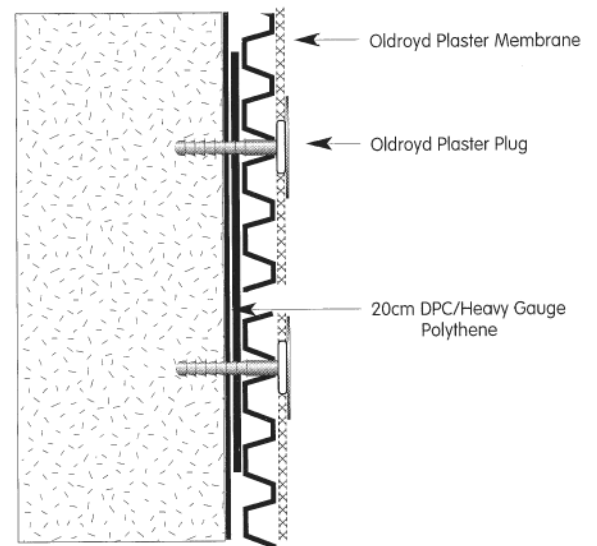

DIAGRAM 6
Incoming Service Collar

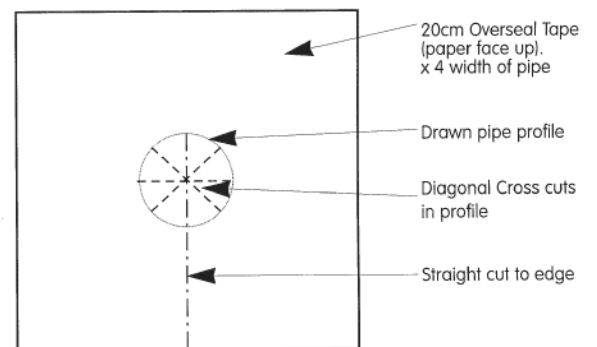
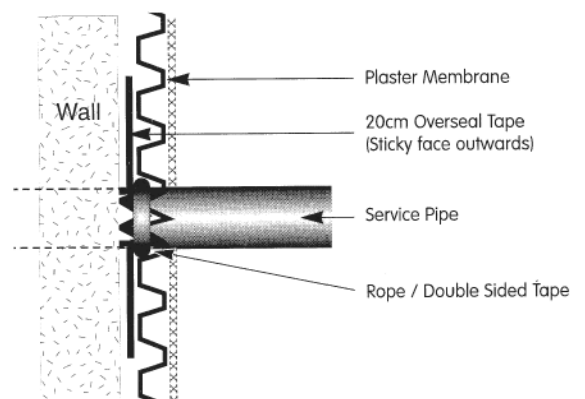

DIAGRAM 7
Incoming Service Collar in position



**SECTION****5.0****MEMBRANE AIR GAP VENTILATION**

At most times of the year within a property positive vapour pressure exists which 'coupled with the relative humidity affects the rate of surface evaporation from a wall surface internally. The air gap behind Oldroyd Plaster Membrane easily absorbs any vapour released and this may be dissipated with a small amount of ventilation. It is often adequate to vent directly into the floor or roof void above by creating small holes at the wall/ceiling junction which are subsequently concealed by the membrane and plaster.

SECTION**6.0****PLASTER FINISHES**

It is important to note that it is necessary to vary fixing centres dependent upon the finish to be applied. In all cases any plaster/render should be applied in strict accordance with the manufacturers' instructions as well as good plastering/rendering practice outlined in the BS5492 and BS5262 Codes of Practice. The minimum depth of plaster/render to be applied should be 15mm. To ensure a good mechanical key the first coat should be applied with firm pressure to a thickness approximately 6mm proud of the membrane surface and scratch finished to provide a key for the subsequent floating coat. Once the first coat has set and dried a 6mm floating coat should be applied and again scratch finished to form a key for the setting coat. Once the floating coat has set a 3mm setting coat may be applied. Various wall finish materials together with the appropriate fixing centres one described below:

6.1 Tilcon White Wall

Fixing centres should not exceed 300mm. This is a pre-mixed bagged plaster which is very suitable for use internally.

6.2 Sand & Cement Renders For Internal Use

Fixing centres should not exceed 300mm. Renders do not possess the flexural properties and elasticity of pre-bagged plaster unless modified by additives. Each coat should be made up of 6 : 7 : 1 sharp washed sand : lime : cement. At least 10 days should be allowed between coats to minimise the possibility of shrinkage cracks, but even so some may still occur. Sand and Cement renders are not recommended for ceilings or barrel vaults.

6.3 Dry Lining

Oldroyd P Plaster Membrane is suitable for use in conjunction with 'Dot & Dob' plaster board dry lining

techniques. Apply the plaster board bonding compound onto the Plaster Plug fixing heads so that at least 50% of the mesh face is generously covered with the bonding compound. Temporarily support the weight of the plaster board whilst the adhesive cures.

6.4 External Use

Oldroyd P Plaster Membrane is suitable for external use above ground level when a surface has suffered deterioration as a result of the actions of the elements. It also provides an instant solution to persistently troublesome exposed elevations, yet due to the air gap behind the membrane, provided it is ventilated at the top and bottom the essential vapour permeability of the wall is unaffected. Men used externally fixing centres should be reduced to 150mm.

Oldroyd P Plaster Membrane provides an instant waterproof mechanical key for external render finishes. These should be applied in accordance with BS5262 in three coats, each made up of 6 : 1 : 1 sharp washed sand : lime : cement. At least seven to ten days should be allowed between each coat. Expansion joints should be incorporated into and brought through each coat vertically over the naturally forming seams i.e. every 1.9m and at least every 2m horizontally. The final coat expansion joint should be concealed by a suitable matching flexible filler. With all render coats, it should be noted that shrinkage cracks one prone to occur but this will have no effect upon the membrane. A pebble dash or stippled finish is less likely to reveal any cracks.

NOTES:

- 1) Do not apply any decoration onto newly plastered surface until it is totally dry.
- 2) Adequate natural ventilation or powered extraction, preferably with a humidistat control, should always form part of a damp-proofing programme especially when membranes are applied internally.
- 3) No responsibility can be accepted by Oldroyd or ChemBuild Ltd for the performance of any plaster or render applied over Oldroyd Plaster Membrane or any associated workmanship.
- 4) In below ground situations where running water is possible, consideration should be given to using an alternative Oldroyd Membrane that requires less mechanical fixing. Please ask our technical department for guidance.

Free Technical Support 01202 601701

ChemBuild Ltd
Unit 36A Bridge Street
Sturminster Marshall
BH21 4DB
Dorset, United Kingdom
Telephone: +44 (0) 1202 601 701
Fax: +44 (0) 1202 604 300
E-mail: sales@chemicalbuildingproducts.co.uk
Web: www.chemicalbuildingproducts.co.uk

